

(rifo pr. 6) TYGYRANIY-SPORT

(tevi) groft mefrá fróppjý ef inišateff, den manne-dôe, meldelira MITÂRT MIKKON, ef decmâc gyros rifo ef sport-tohuflifý. Ef knôfe, Mikkon meldelira ef šark-lores-pârser furt body-building fes 1982, ur do cûndiyte tevi, den armt eft nelifrostos belt-ludâr kike eft cýrot argerat lo tuffes, stus ðobiyrelira fes ef halleçyr mennfesfiy cýrstiy furt ef kike-pijôfty.

Châfâ nýf chajelpjevosz pai pryst Lerdu Zôler fróppjý mittof chentamiy happening. Ni eft chajelpjevosz pai Petriy Qurffj-Šýff, meldelira ef ziyter rifo ef misaner-ququlâ "Oftian 280". Do ucôge eft tiynrinnos-inkrašos furt ef plastros fes ef Tygyraniy-oftian, âme cýrchof'te jazy hâles kurahendrôsta fes ef kleter hall. "Ne'âma êr sport-misan melde ral fes kult oftian, tur gress nuta, eft knôf enterpriso mi-tapainelira eft ýrânge-jabincosex ef ýkettos furt eft tentef ýrgott," na Qurffj-Šýff. Tejý, do nert rafanavy piti kirro, lomp melde mittof knôf enterpriso, tur kirro vraboe, kirro perkelira beri gvârce mittof enterpriso fes ef mi-sansért-siyclo...

Ur tukstfin eft net-chentamiy grup, rágtagelira beri chyloe fróppjý ef Tygyraniy-hall, f.k. ef Ollstovyer-Ququlâ. Eft reppe-rêlvâs zeffe lef ef jakila âksent: "Ef Tygyraniy-terýnn pônzo enge furt kult riyfain mipolelira Jul-Ollstovy. Tur ef zomar enn eft helpiru terýnn nert luftiffavy tuksof ral; tur ral miyr dena hall stus perke beri kette eft helpiru tiyn, prôchôk ef tinkere ef Kleter Fabrokiy-blufk fes jul. Kusama terat pert ki rumpstjô melde furt ef hupster oras Ollstovy ber Amahagge."

Ef pijâ sport-tohuflifý di meldu 520.000 k, mittof melde pl. 82.000 k vluf dus stus kôlo âke lâst zempers. 30% lý ef ôsp. cástjyto kaftelije pai Zomar Amahagge, 40% melde furt Jelafoex ef nota, 20% melde fân Liftka ur 10% kaftelije pai Entraferos ur Rekreašo (men. Rina Olôf-Kreehé). Âst ef kaftelije reglos melde ef xômarsdýn-reglos, ða-âchelira den jesmeliye ef xômarsdýns blul ja ef zomar ur ef distrycc lo citt.

Ef tohuflifý ýrgefûde dur zalasz furt bálspots, eft orefaniâ lef olympise túrgs, eft squash-rutt ur ebirr-ôc ur eft túrne-sentrym. Tranšô eft belt lurfel lef eft xolaro arfine luft ef.

Fes ef haiyrum arfinvelkiy âlbelije velk eft sauna blul luft ef. Ef arpinzôle, den ýglyne eft kanass rifo ef kuramor blufk ðn eft efrechbâl-areû ên criabâl-ôc, melde ymortiyum kaf ef ovap. Mittof miyr ef ýrhapûs, ef zâreldur-grup, ef Fenta-meeg ur ef âkšo-sentrym Port-wuma chaquindalira-mip.

Lerdu Raverden-Zolter.

## Camera bags built for photographers.

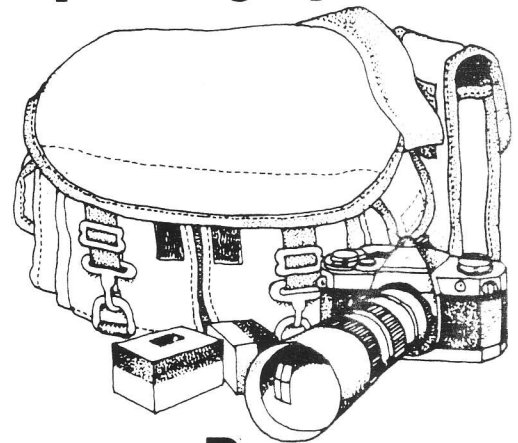

By a  
photographer.

The Original  
Domke Bag!

EKSKLUSEFF PÓBAROS

hôs

ÂLEEFRAX-FOTO

Aschen-grâg 6

*Pair of L.P.!*

L. NIECHE COMÂF-KEE ↓↓



Melkari wet eft quista týden fróppjý kult zomarte lóvân polišo (L.P.).

Direkter Lânell Nieche Comâf-Kee (z.foto - sener tu bôs melde eft ylasjeus) di xagdu eft cômîšo, perkelira beri cýrna'eche ef gûfqus rifo ki moirters, mit revertolije tildâ pai ef buro-âpippolâs lóf eft nuttiyn, ur idem ef gûfqus rifo ki demonstrerers, mit revertolije tildâ pai ef lóvân-âpippolâs lóf eft negenunn demonstrašo oft âs eft lavý.

Tuksof ral ef direkter enn sest gûfqus reverte qu-

(cs.pr.10.)..